



TRANSFLUID
trasmissioni industriali

TRANSFLUID'S TECHNOLOGY IN THE NAVAL PROFESSIONAL WORLD

Towerclutches

Oil/Air Clutches

Hydraulic Brakes

Flexible Couplings

Multi Pump Drive

Oil/Air Actuated PTOs

Hybrid & Full Electric System

Variable Fill Fluid Couplings

Costant Fill Fluid Couplings



drive with us

Transfluid

Founded in Milan Italy in 1957, Transfluid has always been a point of reference in the world of industrial transmission equipment and the standard that its competitors measure themselves.

Fluid couplings, variable speed drives, brakes, clutches, couplings and hydraulic transmissions constitute the core of the product line, while ultra-modern technology, careful selection of materials and meticulous assembly are the key ingredients in the recipe that has placed those products at the forefront of the market. Thousands of customers continue to choose Transfluid for the most diverse and demanding applications, knowing they can rely on Transfluid's technical department, where design, engineering and planning experts are always on hand to quickly resolve client's problems.

Italian dynamic innovation, coupled with ongoing staff development and more than fifty years of hard-earned expertise, are the foundation of the company's success.

Transfluid's unique approach has sparked small but important revolutions in the field of heavy-duty transmissions, for which recognition has come in the form of international awards.

Transfluid's catalogue boasts a wide range of products, and each unit produced is tested for safety, quality and durability. Being a world leader in the design and manufacture of fluid couplings, Transfluid has earned a reputation for diligent service, which assures the competence of the applications through careful quality control and on-site technical assistance.

In addition to the Italian Headquarter. Transfluid's broad sales network consists of five branches located in China, France, Germany, Russia and United States and 32 distributors located throughout the world.

Over 50 Years Experience With Fluid Coupling



KFBD - KRDA - KRU Constant Fill Fluid Couplings

Ideal for the latest engines generation to avoid engine stalling during delicate/abrupt maneuvers, typical for marine transmissions.

Suitable for surface propellers

Engineering of surface propeller is simplified by the fluid coupling features, especially for the acceleration phase Up to 1000 kW (1340 hp)

KRU version, with output DIN flange for Universal Joint connection

KRDA with torsional elastic coupling

NO ENGINE STALLING

- Smooth start up
- Top efficiency
- High number of starts, also reversing rotation direction
- Full protection of engine and driven machine from jams and overloads
- Complete torsional vibration absorption by fluid acting as the power transmission element

A drain type Fluid Coupling acting as a Clutch without friction plates

KPT - Variable Fill Fluid Couplings

Smooth engagement and quick disengagement of propeller drive line plus all benefits provided by the fluid coupling features

Speed Variation to 25% of the engine input speed Up to 3350 kW (4450 hp)



Monitorable and controllable by a dedicated Microprocessor MPCB R5 (*)



Tangible benefits of use

Variable Fill Fluid Coupling

Applied on Azimuth Rudder Propeller

The ferry boat can be powered either by one or more engines, constantly protected by the KPT Fluid Coupling



Our Experience at Your Service



More & More Transfluid on Commercial Vessels:

Variable Fill Fluid Couplings and PTOs for:

- Vehicle & Passengers Ferry
- Ice Breaker
- Bunker Barge
- Patrol, Tender, Sport boat (powered by water jet)
- Dredge
- Fast Catamaran
- Fire Fighting Vessel
- Tug
- Sailing Ship
- Life Boat
- Single/Double Hull Tanker
- Fishing Catamarans
- Taxi Boats
- Turistic Vessels

**Lloyd's R. - DNV - RINA -
BV On Board Classifications**

Side Load or In Line Clutch

Remote control operation just by button pushing (self adjusting)

No flywheel pilot bearing needed

HFR, its specific design eliminates side loads on engine flywheel

Kevlar friction discs for PTO life extension and torsional vibrations dampening

Up to 7750 Nm (5715 lb-ft)

Free Standing PTO



For engine front side to drive pump, alternator, splitter box, etc.

HF Oil/Air Actuated Power Take Off



Suitable for disengagement/engagement of water jets impeller

Dedicated Device for a Self Working PTO

Microprocessor Controller MPCB R5 with Can Bus interface according to Communication protocol SAE J 1939.

- Operation monitoring
- Speed control
- Overload detection/protection
- Start up control (smooth acceleration)
- Integrated events logging
- Low/High oil pressure alarm
- High temperature alarm



Dedicated firmware either for Variable Fill Fluid Couplings and for oil/air Actuated PTOs

Hydraulic and air Power Pack for PTO actuation



Single & Multi-Head Pump Drive

- Stub Shaft PTO implement with side load capacity
- Disconnecting SAE B and C wet clutch
- Modular unit from one to eight pump pads
- Face to Face for power up to 1500 kW (2010 hp)
- Input high torsional flexible coupling for vibration dampening

STELLADRIVE

Input & Output side ready for any SAE standard transmission



Oil/air actuated clutches for pump disconnection

Maximum Flexibility For Transmission Package



MPD - STELLADRIVE

Input & Output side ready for any SAE standard transmission



MPD18 with Variable Fill Fluid Coupling

MPD22 with marine gear box



TC14 - 311 R

TOWERCLUTCH

Multi pump heads power take off available for operation of boat auxiliary equipment as winches, bow thruster, rudder, water pump. Fully controlled by a dedicated microprocessor MPCB - R5 mounted on board. (* see page 2)

Applications

*Multiple pump drives
for any vessel requirement*



Propulsion or Auxiliary

SL - Spring Loaded Brakes



Installed on:

Sub-Sea Winch, operating in deep sea water

Main applications:

Life Boat

Off Shore Installation in Oil & Research Development

Static Torque up to 8800 Nm (6510 lb-ft)

SHC - Hydraulic Clutches



Integrated in Water Jet Propulsion System for propeller disengagement and reverse for grid debris cleaning

Dynamic Torque up to 2492 Nm (1838 lb-ft)



Single Pump Drive

SAE Flywheel Flexible Coupling 'RBD' (rubber block drive) & Shaft PTO 'PF-RBD'

RBD for a flexible misalignment compensation
Up to a nominal torque of 5300 Nm (3908 lb-ft)
Up to SAE 18" flywheel

- Ideal to easily connect the engine to:
 - Marine Gear Box
 - Hydraulic pump
 - Splitter Box
 - Single or Double Bearing Alternator



Positive driven machine shaft connection by QD bushing technology
The clamping force of RBD-QD prevents fretting and pitting of the driven shaft
Available in SAE and DIN standard bore
Integrated in the standard scope of supply of KFBD fluid coupling and Stelladrive MPD14



Power Take Off ready to be installed on SAE flywheel and SAE engine housing for side load or U-joint
Strong housing and bearing system for long lasting life
Suitable up to SAE 0-18"

EPS - Electric Propulsion System

The EPS (ELECTRIC PROPULSION SYSTEM) provides innovative electric propulsion through the combination of standard TRANSFLUID products. Integrating standard components and adhering to SAE standards produces a new product which easily interfaces with any user and application. When used with commercial vehicles, the EPS system includes an automatic "Powershift" RANGERMATIC or REVERMATIC transmission. For marine propulsion the REVERMATIC marine gear uses the reliable RBD coupling. Both transmissions can be installed with Transfluid's permanent magnets electric motor. This improves the operations of the vehicle or boat by using the efficiency and performance of the electrical machine.

The innovative concept of the marine EPS REVERMATIC11-700 RBD marine gear coupled to the electric motor allows you to maximize the maneuverability of the boat and to increase the performance of the electric motor. The reduction ratio of the marine gear allows the user to size the propeller of the boat to demand the maximum power delivered by the electric motor, fully exploiting the motor power and speed. The reverse function is performed by the REVERMATIC11-700 RBD marine gear. This protects the electrical components from transient current peaks. In addition, the EPS Marine system can be used as an extra drive system on large power engines by connecting the output of the EPS system to the PTO (commonly called PTI in marine transmission).

To optimize the performance of the motor a DROP BOX DP280 can be mounted on the output of the EPS system, before to PTI, to provide additional gear ratios optimizing the motor torque output. An example:

By using a compact EPS system weighting only 220 kg, powered at 300 V dc, it is possible to obtain on the PTI a torque of 2750 Nm, a very interesting value for the propulsion of large boats.

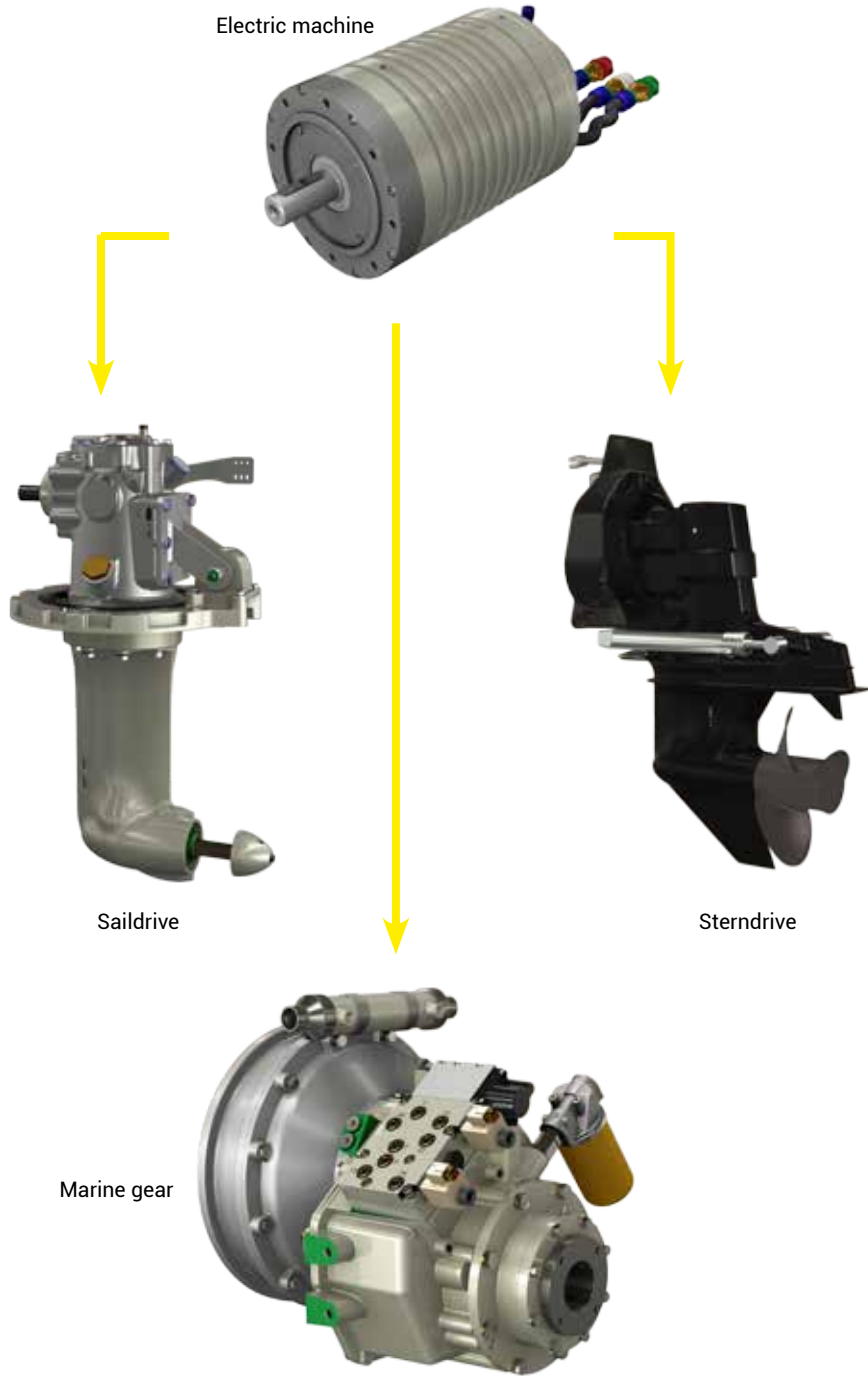

TYPE	POWER at 3000 rpm kW (hp)	NOMINAL TORQUE Nm (lbs-ft)	BATTERY VOLTAGE Vdc	NOMINAL CURRENT A	WEIGHT kg (lbs)	TRANSMISSION	TRANSMISSION	TRANSMISSION
EPS08	8 (11)	25 (18)	96	85	25 (55)	Marine gear	Sail drive	
EPS 12	12 (16)	38 (28)	96	125	35 (76)	Marine gear	Sail drive	
EPS15	15 (20)	47 (35)	96	148	45 (98)	Marine gear	Sail drive	
EPS20	20 (27)	64 (47)	96	170	55 (120)	Marine gear	Sail drive	Stern drive
EPS35	35 (47)	111 (82)	288	135	80 (175)	Marine gear	Sail drive	Stern drive
EPS50	50 (68)	159 (117)	288	170	135 (295)	Marine gear		Stern drive
EPS75	75 (102)	239 (176)	288	289	185 (404)	Marine gear		Stern drive
EPS100	100 (134)	318 (235)	384	370	195 (425)	Marine gear		Stern drive

Electric machine

TRANSFLUID manufactures for its hybrid modules three-phase, permanent magnet, synchronous electric machines (PMSM Permanent Magnet Synchronous Machine) with natural convection air cooling. This solution ensures high efficiency and simplicity with a limited weight and size. The electric machine PMSM is controlled by a Motor Controller (Frequency Drive) that allows to work both as a motor and as a generator. The perfect integration of the range of electric machines with the controllers allows for a compact installation of the system, as well as makes management easy and effective during any operation stage.



HM Series For Green Power And Fuel Economy

Based on consolidated standard products utilized for marine and industrial heavy duties
Ecological sustainability emissions (gas and noise)

Fuel saving

SAE engine and SAE transmission

No need of large space

Possibility of vessels retrofitting against low costs

Powered by electric or engine propulsion or booster modes



- HM560 Hybrid Module
- SAE 4 to SAE 4 distance = 305 mm
- Max input power 180 kW @ 3800 rpm
- Max tot electric input power: 35 kW @ 3000 rpm



- HM2000 Hybrid Module
- SAE 3 to SAE 3 distance = 483 mm
- Max input power 435 kW @ 3000 rpm
- Max tot electric input power: 2x75 kW @ 3000 rpm



- HM3350 Hybrid Module
- SAE 1 to SAE 1 distance = 593 mm
- Max input power 620 kW @ 2300 rpm
- Max tot electric input power: 2x100 kW @ 3000 rpm



- HM6300 Hybrid Module
- SAE 1 to SAE 0 distance = 791 mm
- Max input power 1100 kW @ 2100 rpm
- Max tot electric input power: 2x100 kW @ 3000 rpm

TRANSFLUID

trasmissioni industriali



ITALY

TRANSFLUID S.p.A.
Via Guido Rossa, 4
21013 Gallarate (VA)
Ph. +39.0331.28421
Fax +39.0331.2842911
info@transfluid.it

CHINA

TRANSFLUID BEIJING TRADE CO.LTD
101300 Beijing
Ph. +86.1060442301-2
Fax +86.1060442305
tbtcinfo@transfluid.it

FRANCE

TRANSFLUID FRANCE s.a.r.l.
38110 Rochetoirin
Ph. +33.9.75635310
Fax +33.4.26007959
tffrance@transfluid.it

GERMANY

TRANSFLUID GERMANY GmbH
D-48529 Nordhorn
Ph. +49 5921.7288808
Fax +49 5921.7288809
tfgermany@transfluid.it

RUSSIA

TRANSFLUID OOO
143100 Moscow
Ph. +7.495.7782042
Mob. +7.926.8167357
tfrussia@transfluid.it

U.S.A.

TRANSFLUID LLC
Auburn, GA 30011
Ph. +1.770.8221.777
Fax +1.770.8221.774
tfusa@transfluid.it



www.transfluid.eu
www.buy-transfluid.com



drive with us